

Track End View

**BILL OF MATERIALS:**

- Ramp:
  - 53 8x12x12' Planks
  - 4 12x16x55' Joists
  - 2 8x12x55' Guard Rails
- Platform:
  - 16 8x8x12' Planks
  - 4 12x16x12' Joists
  - 2 8x12x12' Guard Rails
- Bridge:
  - 4 8x12x12' Planks
  - 2 12x12x4' Joists
  - 1 6x6x12' Stop
- Bents (above ground):
  - 4 12x12x12' Bent Caps
  - 4 12x12x122" Bent Legs
  - 2 12x12x86" Bent Legs
  - 2 12x12x49" Bent Legs
  - 14 4x12x16' Bent Braces (cut as needed)
- Misc:
  - 1 6x12x12' Winch Post
  - 1 Winch & Cable
  - 1 Set of suitable hinges

Minneapolis & St. Louis Railroad  
 Coal Loading Ramp  
 Oskaloosa, Iowa  
 ca. July 1961  
  
 Drawn from memory & photo  
 6/28/91 by Sam Cook

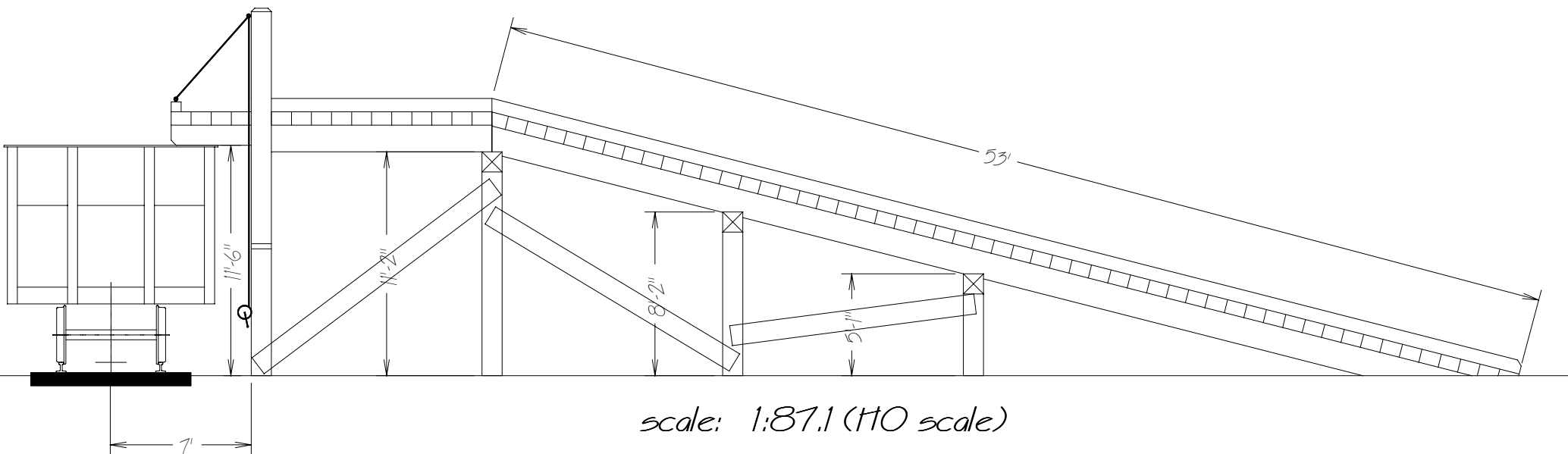
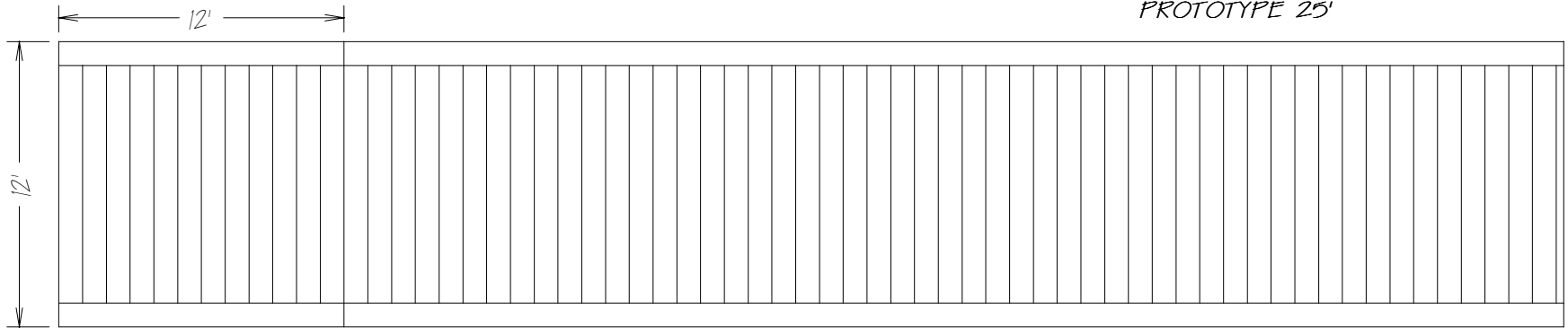
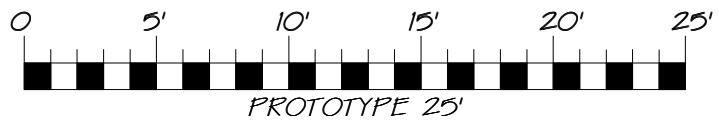

scale: 1:87.1 (HO scale)